



# BIOGUARD ACOUSTIC

(ISO 5)





[www.armstrong-ceilings.co.uk](http://www.armstrong-ceilings.co.uk)  
[www.armstrong-ceilings.ie](http://www.armstrong-ceilings.ie)

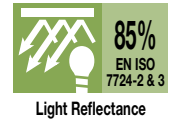

# BIOGUARD ACOUSTIC (ISO 5)

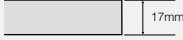
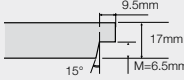
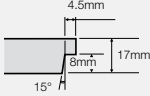

## BIOGUARD

	BOARD	TEGULAR	MICROLOOK
			
	Prelude XL <sup>2</sup> /TLX / CR 24 mm Clean Room Grid 24 mm	Prelude XL <sup>2</sup> /TLX 24 mm Clean Room Grid 24 mm	Prelude XL <sup>2</sup> /TL 15 mm Interlude XL <sup>2</sup> 15 mm
			
600 x 600 x 17 mm	2549 M	2551 M	2552 M
600 x 1200 x 17 mm	2550 M		



EN ISO 354 &  
EN ISO 11654

$\alpha_w$	NRC	125	250	500	1000	2000	4000	Hz
0.60(H)	0.60	0.35	0.40	0.50	0.70	0.85	0.90	$\alpha_p$

Sound Absorption Class = C

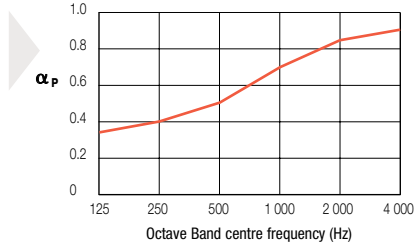

EN ISO 10848-2  
& EN ISO 717-1

<b>D<sub>nfw</sub></b>	<b>36 dB</b>
------------------------	--------------



EN ISO 140-3  
& EN ISO 717-1

<b>R<sub>w</sub></b>	<b>18 dB</b>
----------------------	--------------



EEA Euroclass A2-s1, d0
EN 13501-1

RUS KM1 (G1, V1, D1, T1)
FZ 123



EN 12667  
& ISO 8301

$\lambda = 0.06$  W/m K



ISO 14644-1

ISO 5



95 % RH



15 YEAR  
guarantee



30 YEAR  
system  
guarantee



3.8 kg/m<sup>2</sup>

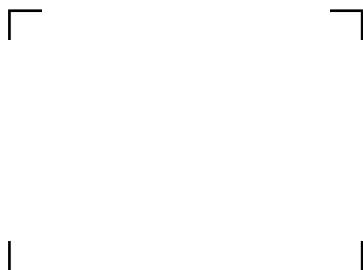

Please contact our Armstrong Technical Sales Group for further details.

**United Kingdom**  
Armstrong World Industries Ltd.  
Building Products Division  
38 Market Square,  
Uxbridge UB8 1NG  
Freefone 0800 371849  
Fax: (+44) 1895 274287

[www.armstrong-ceilings.co.uk](http://www.armstrong-ceilings.co.uk)

**Republic of Ireland**  
Armstrong World Industries Ltd.  
Sales Office  
108 Greenlea Road - Terenure  
Co Dublin 6W  
Freefone 1800 409002  
Fax: (+353) 1 490 7061

[www.armstrong-ceilings.ie](http://www.armstrong-ceilings.ie)

[www.armstrong-ceilings.co.uk](http://www.armstrong-ceilings.co.uk)  
[www.armstrong-ceilings.ie](http://www.armstrong-ceilings.ie)

